

錫鋼 3刃立銑刀

TUNGSTEN CARBIDE 3-FLUTE SQUARE END MILL

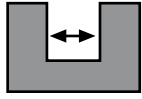

$d \leq 3$	-0.005 ~ -0.028
$3 < d \leq 6$	-0.015 ~ -0.038
$6 < d \leq 18$	-0.020 ~ -0.047
$18 < d$	-0.020 ~ -0.053

- 超細微粒碳化錫材質
- Micro-Grain Tungsten Carbide

適用材質：

碳素鋼、模具鋼、合金鋼、
工具鋼、鑄鐵、不鏽鋼、
熱處理鋼、焊補鋼料。

Applicable materials:

Carbon steel, mold steel,
alloy steel, tool steel, cast iron, stainless steel,
heat-treated steel, welded steel.

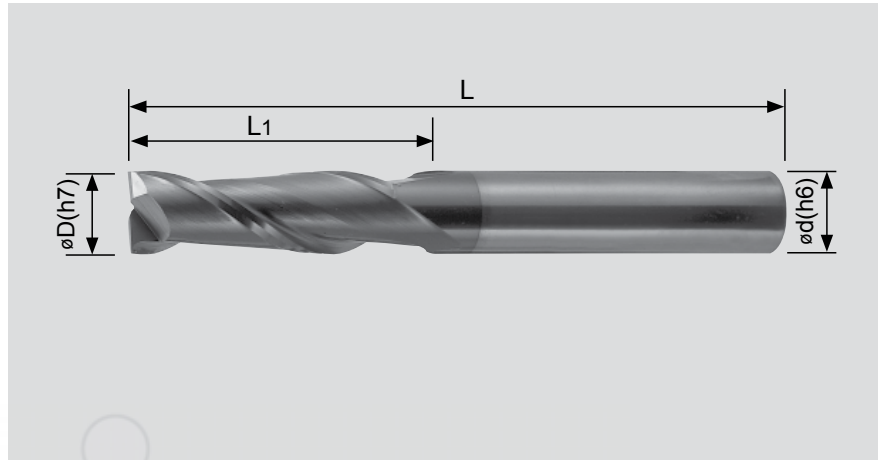

單位: Unit : mm

型號 EDP NO.	刃徑 D Flute Dia.	刃長 L1 Length of Cut	全長 L Overall Length	柄徑 d Shank Diameter	刃數 Flute Number	AK45	AK925	PK66
3E-D3.0L50	3.0	8.0	50	4.0	3	●	●	●
3E-D4.0L50	4.0	10.0	50	4.0	3	●	●	●
3E-D3.0L50-6	3.0	8.0	50	6.0	3	●	●	●
3E-D4.0L50-6	4.0	10.0	50	6.0	3	●	●	●
3E-D5.0L50	5.0	13.0	50	6.0	3	●	●	●
3E-D6.0L50	6.0	15.0	50	6.0	3	●	●	●
3E-D7.0L60	7.0	20.0	60	8.0	3	●	●	●
3E-D8.0L60	8.0	20.0	60	8.0	3	●	●	●
3E-D10.0L75	10.0	25.0	75	10.0	3	●	●	●
3E-D12.0L75	12.0	30.0	75	12.0	3	●	●	●
3E-D14.0L75	14.0	35.0	75	14.0	3	●	●	●
3E-D16.0L100	16.0	45.0	100	16.0	3	●	●	●

註: 有●者表示有庫存

NOTE: ● means items in stock

切削條件表請參考第76頁